

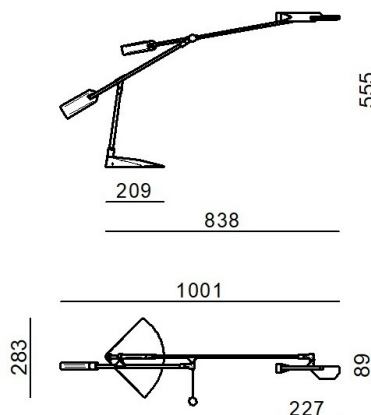

Lámpara de mesa | 230-240 V  
16 topLED 8 W DC - 9 W AC | CRI 90

9586M



Datos técnicos	
Posición de instalación	Piso
Ambiente de instalación	Interiores
Fuente de luz	LED
Circuit structure	topLED
Óptica	Difusa
Light emission direction	downward
Potencia nominal	8 W DC
Poder total	9 W
Flujo luminoso (fuente)	1040 lm
Voltage	230 - 240 V AC
Frequency	50 - 60 Hz
CCT / Tone	2700 K
Índice de rendimientos cromático	90 Ra
C.C. / C.V.	AC
Clase de aislamiento	2
IP	IP20
Test del hilo incandescente	850°
Montaje directo sobre superficies normalmente inflamables	Sí
CE	Sí
Driver incluido.	driver
Artículo regulable	Touchless Dimmer
Orientabilidad	Orientabile
ángulo total (plano vertical)	360 °
ángulo total (plano horizontal)	360 °
Basculación	No
Practicabilidad	No
Transitabilidad	No
Cable incluido.	Sí
Enchufe eléctrico	Type C
Largo del cable	3 m
Resinado	No
Tipología de emisión luminosa	Una emisión
Peso neto	4.250 Kg
Protección descargas electrostáticas	No
Protección contra sobretensiones	No

Acabado cuerpo	
Material	aluminio
Color	Negro
Elaboración	Pintura
Acabado difusor	
Material	PC
Color	transparente
Acabado base	
Material	Zamak
Color	Negro
Elaboración	Pintura

## Lámpara de mesa | 230-240 V | 16 topLED 8 W DC - 9 W AC | CRI 90 9586M

Single emission table lamps for indoor application. The super warm LED light source with a diffused light distribution is composed of 16 topLED LEDs with CCT of 2700 K and a CRI 90; the source luminous flux is 1040 lm, with a 130.0 lm/W nominal luminous efficacy.

The device body is made of aluminium and features a black finish, processed by means of coating; the diffuser is made of PC. The ingress protection degree is IP20; the total weight is of 4.250 kg.

The total absorbed power is 9 W. The power supply cable is included and features a 3 m length.

The device features protection class II and can be floor-mounted.

Compliant with the EN 60598-1 standard and its specific provisions.

### Características Luminotécnicas

Light Output Ratio (LOR)	50 %
Flujo luminoso (fuente)	1040 lm
Flujo luminoso de luminaria	529 lm
Consumption	9 W
Rendimiento luminoso de las luminarias	58 lm/W
Temperatura de color	2700 K
Standard Deviation of Colour Matching	3 Step MacAdam
Índice de rendimientos cromático	90 Ra
Temperatura de unión (luminaria)	80
Temperatura estándar del ambiente de servicio	25°C

### LED Life / Failure Ratio

L70 B20 C0 72500h (at Tj 115 Ta 25 )

### UGR

UGR axial	25.4
UGR transversal	25.1
X=4H   Y=8H	S=0.25H
Reflection factor	70/50/20

### OPTICAL

Óptica C0/C180	86°
Light distribution symmetry	Symmetrical

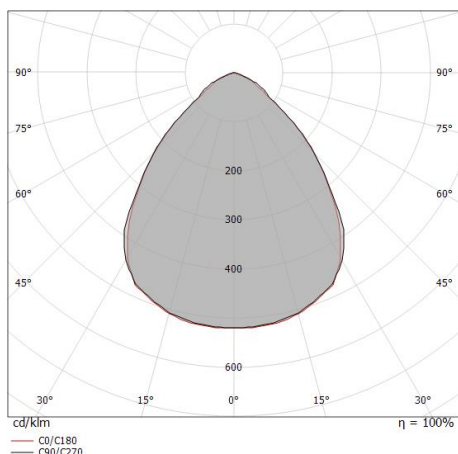

Distance [m]	Cone diameter [m]	Illuminance [lx]
0.5	0.93 0.93	E(0°) 1100 E(C90) 217 E(C0) 219
1.0	1.86 1.85	E(0°) 275 E(C90) 54 E(C0) 55
1.5	2.79 2.78	E(0°) 122 E(C90) 24 E(C0) 24
2.0	3.72 3.70	E(0°) 69 E(C90) 14 E(C0) 14
2.5	4.65 4.63	E(0°) 44 E(C90) 9 E(C0) 9
3.0	5.58 5.56	E(0°) 31 E(C90) 6 E(C0) 6

Distance [m] Cone diameter [m] Illuminance [lx]

— C0/C180 (Half-peak divergence: 85.6°)  
— C90/C270 (Half-peak divergence: 85.8°)