

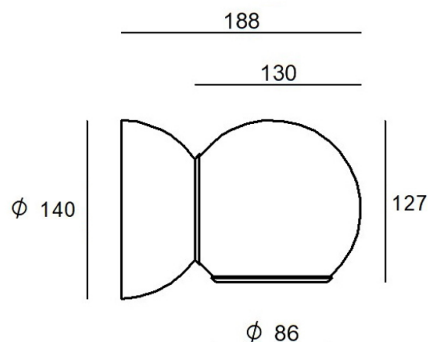

Wandleuchten | 220-240 V
1 arrayLED 9 W DC - 11 W AC | CRI 90

9720



Technische Daten	
Typ	Wandleuchten
Installationsposition	Wand
Installationsumgebung	Indoor
Lichtquelle	LED
Optik	Diffuses
Light emission direction	downward
Lampe Nennleistung	9 W DC
Gesamtleistung	11 W
Lichtstrom (Lichtquelle)	1079 lm
Voltage	220 - 240 V AC
Frequency	50 - 60 Hz
Ähnlichste Farbtemperatur / Tone	3000 K
Farbwiedergabeindex	90 Ra
Gleichstrom/Gleichspannung	AC
Isolierklasse	1
IP	IP20
Glühdrahtprüfung	850°
Direkte Montage auf normal entflammaren Oberflächen	Ja
CE	Ja
Einschließlich Driver	Driver
Leuchte dimmbar	Phase cut
Schwenkbarkeit	Orientabile
Gesamtwinkel (horizontale Ebene)	360 °
Drehbarkeit	Nein
Begehbarkeit	Nein
Überrollbarkeit	Nein
Einschließlich Kabel	Nein
Harzbeschichtung	Nein
Typ Lichtabstrahlung	Einflammig
Nettogewicht	1.330 Kg
Schutz vor elektrostatischen Entladungen	Nein
Schutz vor Stoßspannungen	Nein

Oberfläche Gehäuse

Material	Eisen
Farbe	Weiß RAL 9016
Bearbeitungstyp	Lackierung

Oberfläche Diffusor

Material	PC
Farbe	transparent

Oberfläche sockel

Material	Eisen
Farbe	Weiß RAL 9016
Bearbeitungstyp	Lackierung



Wandleuchten | 220-240 V | 1 arrayLED 9 W DC - 11 W AC | CRI 90
9720

Single emission wall lights for indoor application. The warm white LED light source with a diffused light distribution is composed of 1 topped LEDs with CCT of 3000 K and a CRI 90; the source luminous flux is 1079 lm, with a 119.9 lm/W nominal luminous efficacy.

The device body is made of iron and features a white ral 9016 finish, processed by means of coating; the diffuser is made of PC. The ingress protection degree is IP20; the total weight is of 1.330 kg.

The total absorbed power is 11 W.

The device features protection class I and can be wall lights-mounted.

Compliant with the EN 60598-1 standard and its specific provisions.

Energieeffizienzklasse

ieses Produkt enthält eine Lichtquelle der Energieeffizienzklasse F.

Illuminotechnical Eigenschaften

Light Output Ratio (LOR)	88 %
Lichtstrom (Lichtquelle)	1079 lm
Leuchten Lichtstrom	956 lm
Consumption	11 W
Leuchten Lichtausbeute	86 lm/W
Farbtemperatur	3000 K
Standard Deviation of Colour Matching	3 Step MacAdam
Farbwiedergabeindex	90 Ra
Verbindungstemperatur (Leuchte)	80
Standardumgebungstemperatur	-20 / +50°C

LED Life / Failure Ratio

L80 B20 C0 80000h

UGR

UGR axial	22.8
UGR transversal	22.7
X=4H Y=8H	S=0.25H
Reflection factor	70/50/20

OPTICAL

Optik C0/C180	93°
Light distribution simmetry	Symmetrical

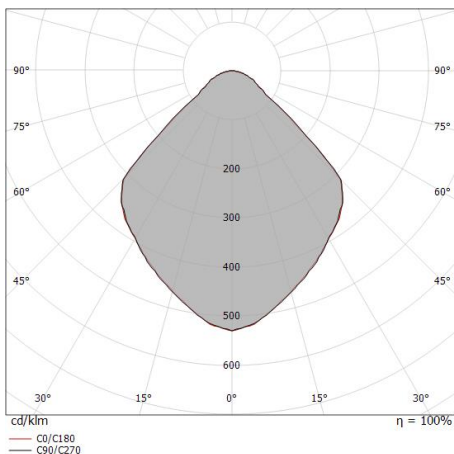

Distance [m]	Cone diameter [m]	Illuminance [lx]
0.5	1.06 1.06	E(0°) 2026 E(C90) 329 E(C0) 330
1.0	2.12 2.11	E(0°) 507 E(C90) 82 E(C0) 83
1.5	3.18 3.17	E(0°) 225 E(C90) 37 E(C0) 37
2.0	4.24 4.23	E(0°) 127 E(C90) 21 E(C0) 21
2.5	5.31 5.29	E(0°) 81 E(C90) 13 E(C0) 13
3.0	6.37 6.34	E(0°) 56 E(C90) 9 E(C0) 9

Distance [m] Cone diameter [m] Illuminance [lx]

— C0/C180 (Half-peak divergence: 93.2°)
 — C90/C270 (Half-peak divergence: 93.4°)